

REBOXING MODEL E INDOOR ROWER

TOOLS NEEDED: hex allen wrench
fiber packing tape



concept2.com

REBOXING BOX 1

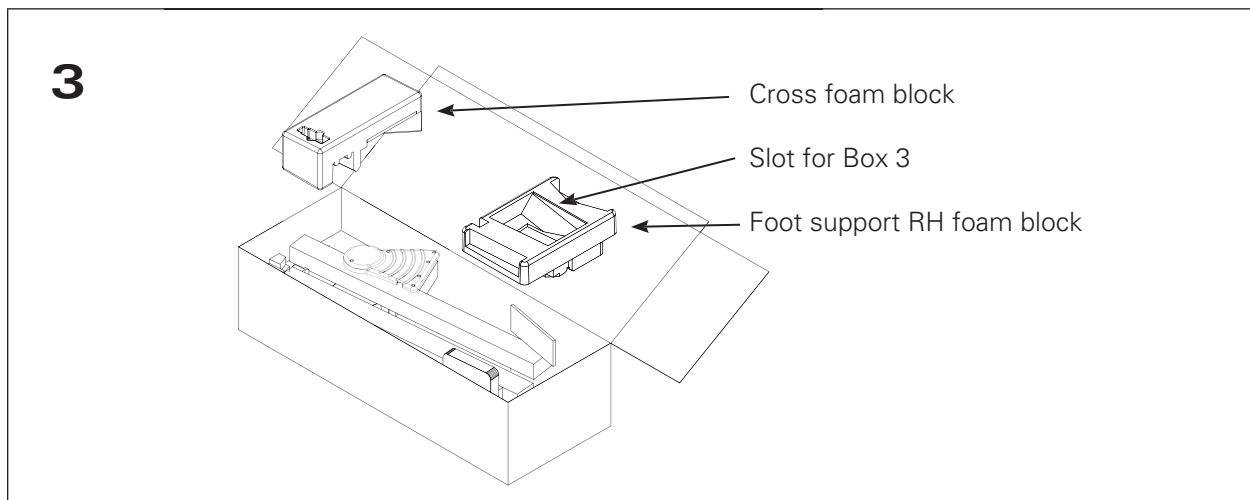
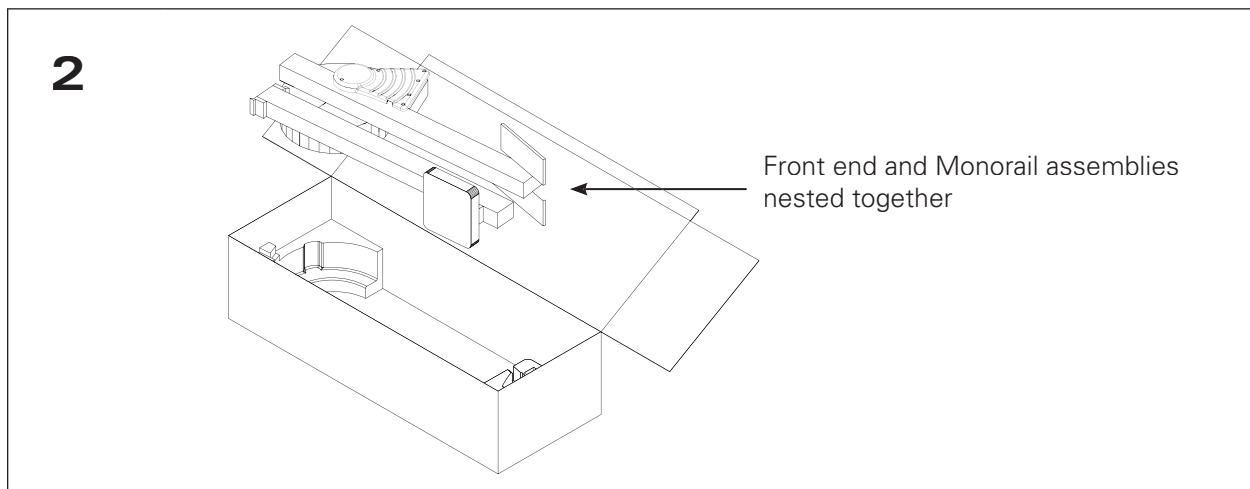
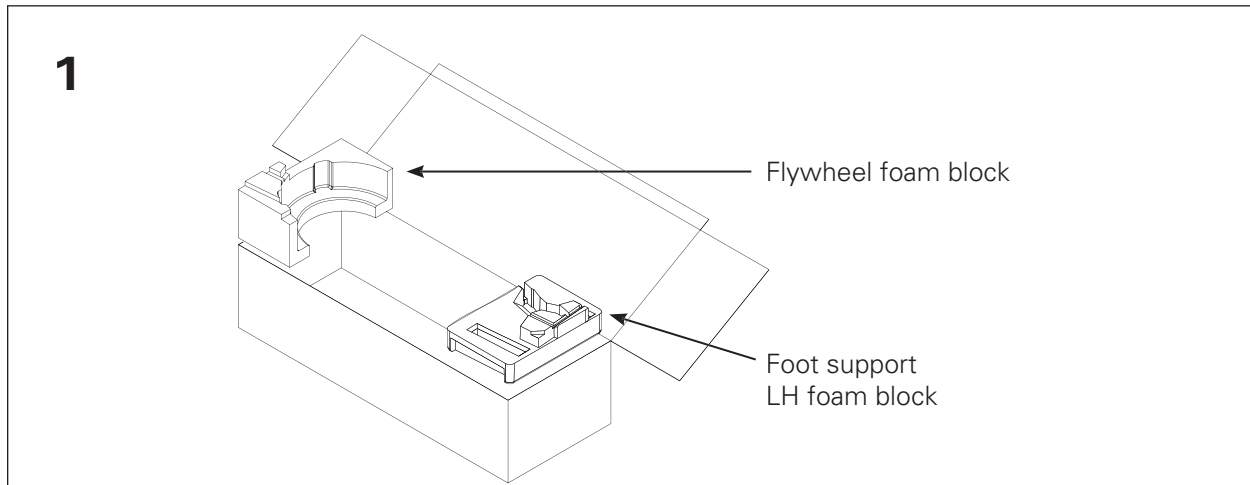

REBOXING MODEL E INDOOR ROWER

BOX 2 Contents

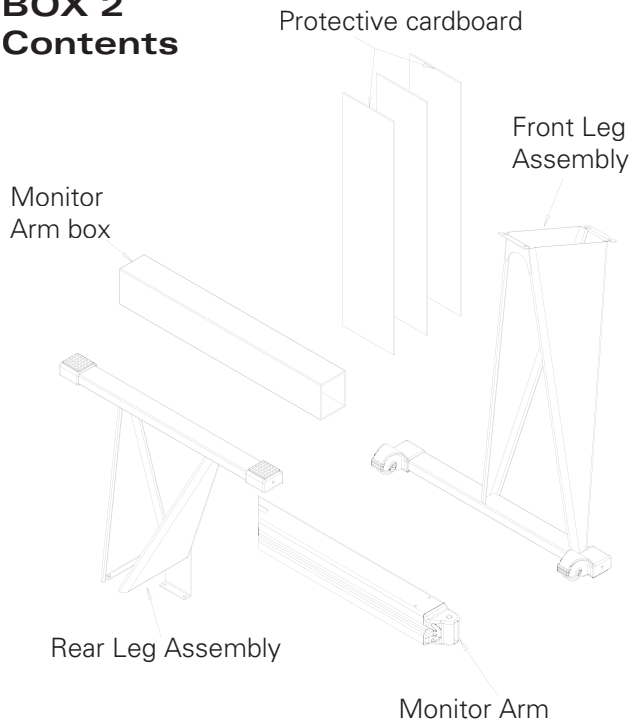

3

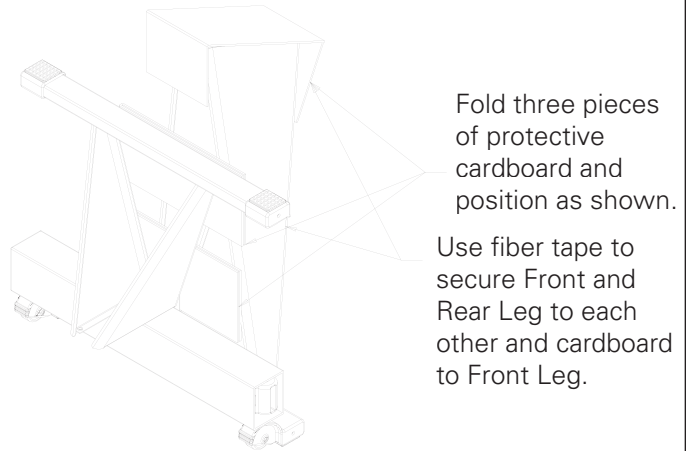

REBOXING BOX 2

1 Place Monitor Arm inside Monitor Arm Box and wrap snugly to Front Leg with fiber tape here.

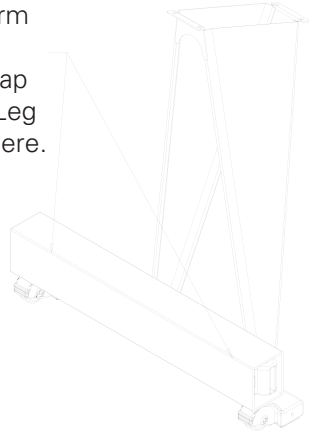

2

Position Rear Leg as shown.



4

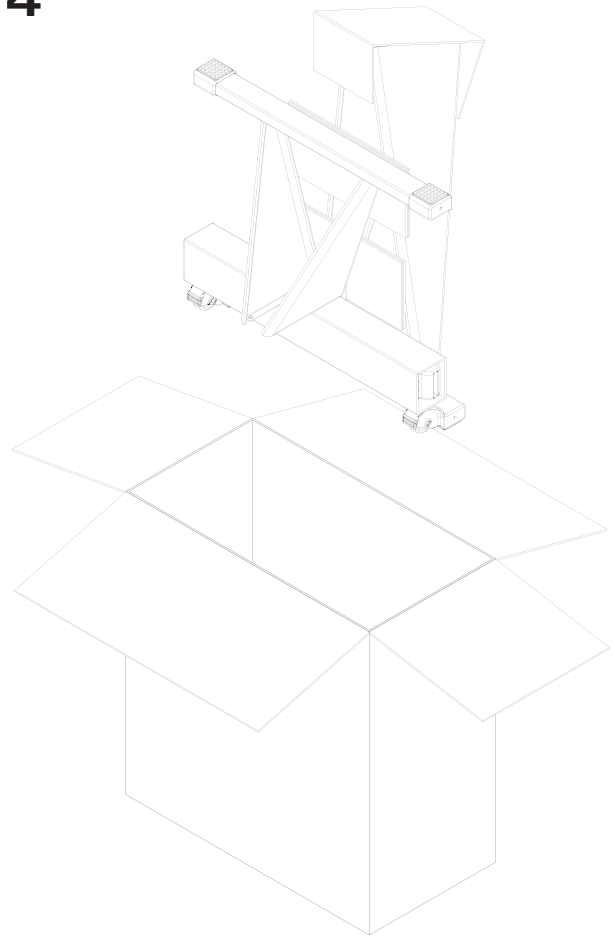

REBOXING BOX 3

Repack Box 3 items, taking care to protect the PM4. Place Box 3 monitor side DOWN into slot in foam in Box 1. See Step 3 on other side for Box 3 location.